

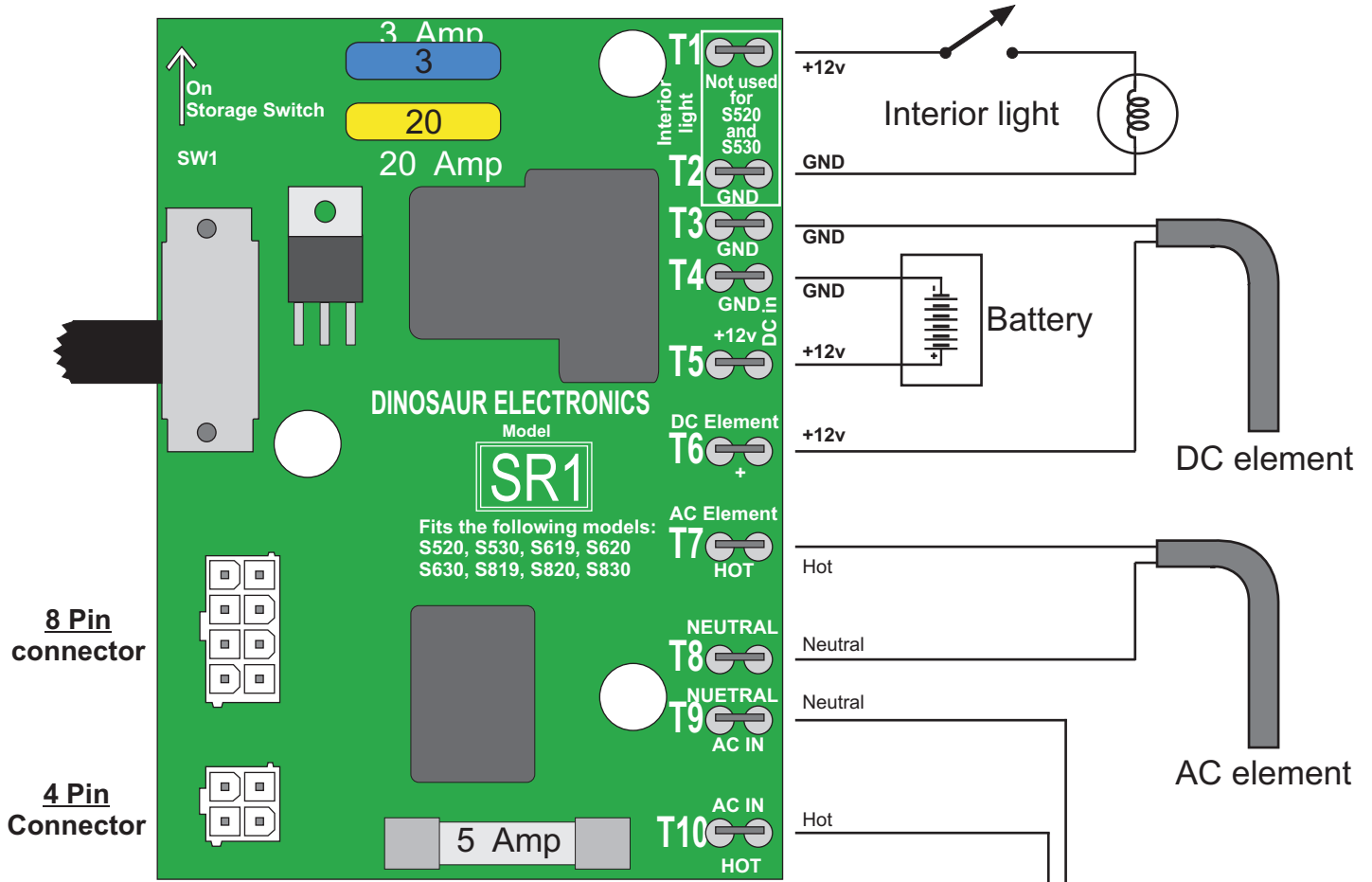

Dinosaur Electronics

1160 SE 27th St.
 Lincoln City, OR 97367
 Ph. (541) 994-4344 Fax: (541) 994-2796

Pinouts for the SR1 Board



8 Pin Eyebrow Connector Pinout

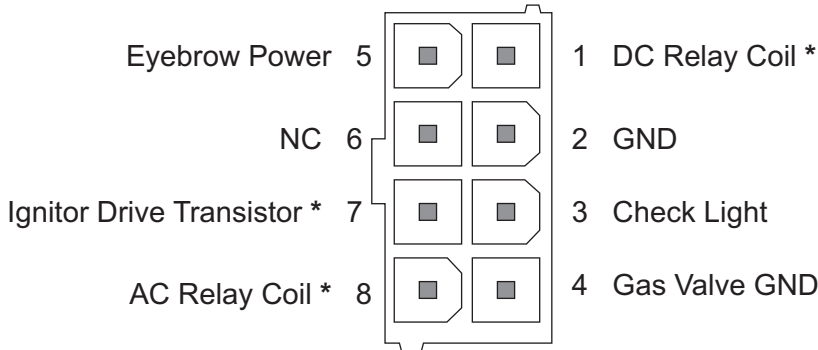

*Note: Pin 1 or 7 or 8 goes to ground for the selected operation

4 Pin Ignitor Module Connector Pinout

